

ALUMINUM ALLOY EQUIPMENT FOR OVERHEAD LINES

032

LINE CART / INSPECTION TROLLEY FOR SINGLE CONDUCTOR

1 lineman towable trolley complete of nylon wheels on ball-bearings, stationary brake, footrest and nylon traps for back support.

Made of welded aluminum alloy (certified TIG system).

Payload: 100 daN

Weight: 12 kg.

Upon request:

- Counter meter device;
- Aluminum wheels.

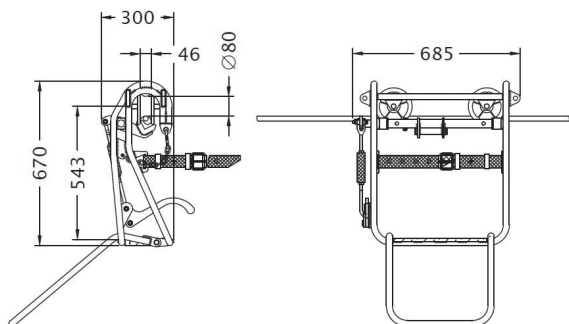

035

LINE CART / INSPECTION TROLLEY FOR SINGLE CONDUCTOR

1 or 2 linemen towable trolley, complete with aluminum wheels on ball-bearings, anti-slip floor, n°2 stationary brakes, safety frame ropes and counter meter device.

Made of welded aluminum alloy (certified TIG system).

Upon request:

- Dynamic disc brake device;
- Nylon wheels;
- Earthing device;
- "Custom-made" size available;
- Anchoring point in compliance with UNI EN 795:2012.

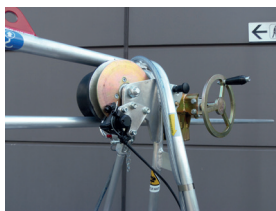
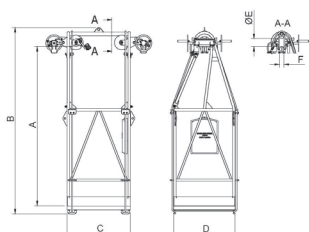

MODEL	N° linemen	A	B	C	D	E	F	Weight	Working load
		mm	mm	mm	mm	mm	mm	kg	daN
035-A	1	1650	1920	650	630	80	46	42	100
035-B	2	1650	1920	1000	630	80	46	46	200

035/L

LINE CART / INSPECTION TROLLEY FOR SINGLE CONDUCTOR

2 linemen towable trolley with large aluminum wheels (Ø 350mm) on ball-bearings with Nylon liners, anti-slip floor, n°2 stationary brakes, safety frame ropes and counter meter device.

Made of welded aluminum alloy (certified TIG system).

Completed with balancing wheels to allow the operator to work on the cantilever (so called "balcony").

Upon request:

- Dynamic disc brake device;
- Nylon wheels;
- Earthing device;
- "Custom-made" size available;
- Anchoring point in compliance with UNI EN 795:2012.

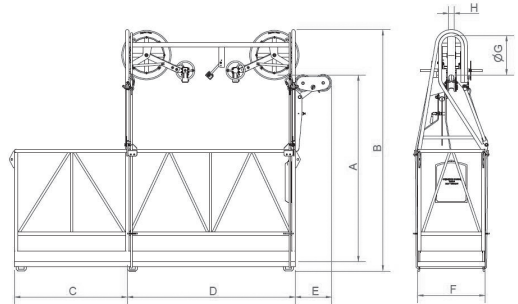

MODEL	A	B	C	D	E	F	G	H	Weight	Working load
	mm	mm	mm	mm	mm	mm	mm	mm	kg	daN
035/L-A	1650	2150	1000	1500	330	600	350	48	90	200

